

1/2 to 1 HP Medium Temperature Platform (Microchannel)

Project Name:	
Customer Name:	
Model Number:	
Refrigerant:	
Job Location:	
Date:	
AWEF:	

SMALL CHASSIS

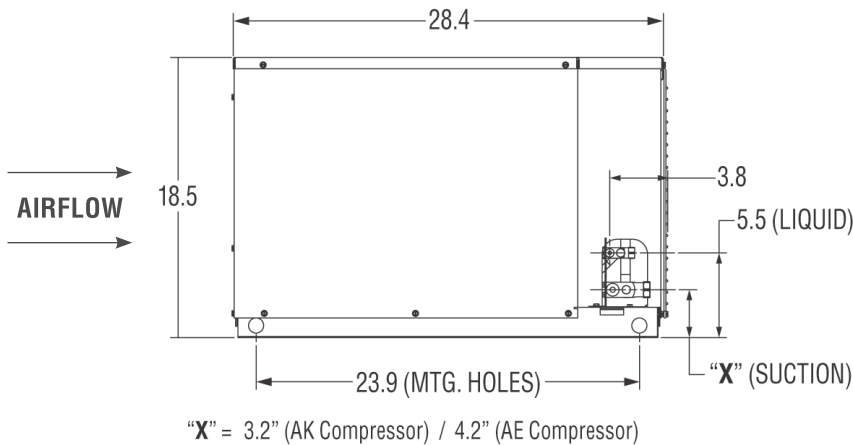
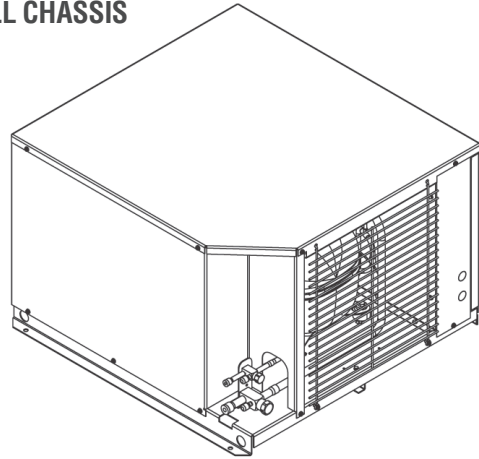

SIDE VIEW

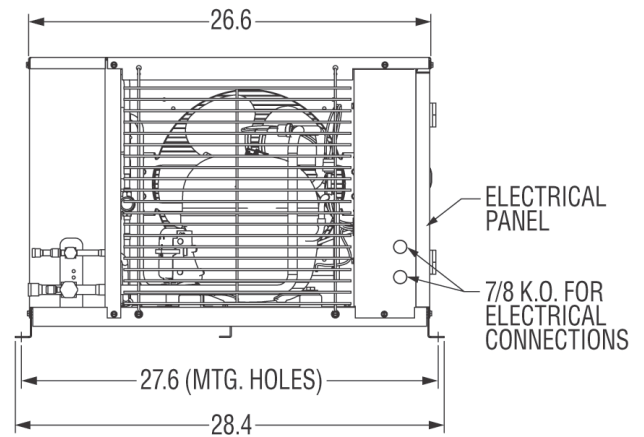

FRONT VIEW

Physical Data

ARGUS Series	Model Number	Compressor		Connections (inch)		Pump Down Capacity* (lbs) 90% @ 90°F Ambient / R-404A		Net Weight (lbs)
		Model Number	HP	Liquid	Suction	Standard	Oversized	
R-404A	AS*R9440ZAA***	AE4450Z-AA3C	1/2	3/8" S	3/8" S	8.04	15.20	150
R-448A	AS*R9440ZNA***	AE4450Z-XN3C	1/2	3/8" S	3/8" S	8.04	15.20	150
R-449A	AS*R9460ZNA***	AK4510Z-NA3C	3/4	3/8" S	5/8" S	8.04	15.20	159
R-452A	AS*R9480ZNA***	AK4513Z-NA3C	1	3/8" S	5/8" S	8.04	15.20	159

*Receiver + Coil Capacity

Electrical Data

Model Number	Power Supply	Compressor		Condensing Unit		Fan Motor (PSC)			Fan Motor (EC)		
	Volts/Hz/Ph	RLA	LRA	MCA*	MOPD	Qty	HP	FLA	Qty	HP	FLA
AS*R9440ZAA***	115/60/1	6.2	34.5	8.8	15	1	1/20	0.85	1	1/20	0.9
AS*R9440ZNA***	208-230/60/1	2.98	22	4.4	15	1	1/20	0.45	1	1/20	0.5
AS*R9460ZNA***	208-230/60/1	5.8	29.9	7.9	15	1	1/20	0.45	1	1/20	0.5
AS*R9480ZNA***	208-230/60/1	7.1	31.3	9.6	15	1	1/20	0.45	1	1/20	0.5

*Add .21 Amps for Heated Receiver

DOE AWEF (AHRI 1250)

AWEF Table	Model Number	Indoor	Outdoor
R-404A	AS*R9440Z*****	5.61	7.60
	AS*R9460Z*****	5.61	7.60
	AS*R9480Z*****	5.61	7.60
R-449A / R-448A	AS*R9440Z*****	5.61	7.60
	AS*R9460Z*****	5.61	7.60
	AS*R9480Z*****	5.61	7.60
R-452A	AS*R9440Z*****	5.61	7.60
	AS*R9460Z*****	5.61	7.60
	AS*R9480Z*****	5.61	7.60

1/2 to 1 HP Medium Temperature Platform (Microchannel)

Performance Tables (R-404A)

80°F AMBIENT						
Model Number	Suction Temperature (SST)					
	30°F	25°F	20°F	10°F	0°F	-10°F
AS*R9440Z*****	5173	4682	4453	3558	2794	2158
AS*R9460Z*****	8630	7846	7483	5973	4610	3390
AS*R9480Z*****	10163	9423	9162	7582	6026	4488

90°F AMBIENT						
Model Number	Suction Temperature (SST)					
	30°F	25°F	20°F	10°F	0°F	-10°F
AS*R9440Z*****	4675	4221	4006	3190	2505	1947
AS*R9460Z*****	7737	7019	6680	5312	4089	3007
AS*R9480Z*****	9411	8713	8457	6969	5503	4054

95°F AMBIENT						
Model Number	Suction Temperature (SST)					
	30°F	25°F	20°F	10°F	0°F	-10°F
AS*R9440Z*****	4426	3991	3782	3006	2360	1841
AS*R9460Z*****	7291	6606	6279	4981	3828	2816
AS*R9480Z*****	9035	8358	8106	6662	5241	3837

100°F AMBIENT						
Model Number	Suction Temperature (SST)					
	30°F	25°F	20°F	10°F	0°F	-10°F
AS*R9440Z*****	4177	3760	3558	2822	2215	1736
AS*R9460Z*****	6845	6192	5878	4651	3568	2626
AS*R9480Z*****	8659	8003	7754	6356	4980	3621

110°F AMBIENT						
Model Number	Suction Temperature (SST)					
	30°F	25°F	20°F	10°F	0°F	-10°F
AS*R9440Z*****	3679	3299	3111	2454	1926	1525
AS*R9460Z*****	5953	5366	5075	3989	3046	2243
AS*R9480Z*****	7907	7294	7049	5742	4457	3187

Performance Tables (R-448A / R-449A)

80°F AMBIENT						
Model Number	Suction Temperature (SST)					
	30°F	25°F	20°F	10°F	0°F	-10°F
AS*R9440Z*****	4720	4223	3947	3041	2261	1606
AS*R9460Z*****	7454	6641	6182	4732	3511	2514
AS*R9480Z*****	9377	8550	8148	6537	5055	3701

90°F AMBIENT						
Model Number	Suction Temperature (SST)					
	30°F	25°F	20°F	10°F	0°F	-10°F
AS*R9440Z*****	4347	3884	3626	2792	2085	1500
AS*R9460Z*****	6768	6016	5588	4266	3173	2303
AS*R9480Z*****	8570	7794	7409	5908	4537	3291

95°F AMBIENT						
Model Number	Suction Temperature (SST)					
	30°F	25°F	20°F	10°F	0°F	-10°F
AS*R9440Z*****	4161	3714	3465	2669	1996	1448
AS*R9460Z*****	6426	5703	5292	4034	3004	2197
AS*R9480Z*****	8167	7417	7039	5594	4277	3087

100°F AMBIENT						
Model Number	Suction Temperature (SST)					
	30°F	25°F	20°F	10°F	0°F	-10°F
AS*R9440Z*****	3974	3545	3305	2545	1909	1395
AS*R9460Z*****	6083	5391	4994	3801	2835	2091
AS*R9480Z*****	7763	7039	6669	5280	4018	2882

110°F AMBIENT						
Model Number	Suction Temperature (SST)					
	30°F	25°F	20°F	10°F	0°F	-10°F
AS*R9440Z*****	3602	3206	2985	2297	1732	1290
AS*R9460Z*****	5398	4766	4401	3335	2497	1880
AS*R9480Z*****	6956	6284	5930	4651	3500	2473

Performance Tables (R-452A)

80°F AMBIENT						
Model Number	Suction Temperature (SST)					
	30°F	25°F	20°F	10°F	0°F	-10°F
AS*R9440Z*****	4950	4477	4244	3362	2588	1919
AS*R9460Z*****	7528	6783	6410	5072	3945	3022
AS*R9480Z*****	9694	8838	8449	6826	5381	4108

90°F AMBIENT						
Model Number	Suction Temperature (SST)					
	30°F	25°F	20°F	10°F	0°F	-10°F
AS*R9440Z*****	4505	4060	3833	3012	2297	1686
AS*R9460Z*****	6847	6144	5781	4534	3495	2660
AS*R9480Z*****	8835	8033	7656	6149	4817	3657

95°F AMBIENT						
Model Number	Suction Temperature (SST)					
	30°F	25°F	20°F	10°F	0°F	-10°F
AS*R9440Z*****	4283	3852	3629	2836	2150	1569
AS*R9460Z*****	6507	5825	5467	4264	3270	2478
AS*R9480Z*****	8406	7630	7260	5810	4536	3431

100°F AMBIENT						
Model Number	Suction Temperature (SST)					
	30°F	25°F	20°F	10°F	0°F	-10°F
AS*R9440Z*****	4060	3643	3423	2661	2005	1453
AS*R9460Z*****	6166	5505	5152	3994	3045	2298
AS*R9480Z*****	7976	7227	6864	5471	4254	3206

110°F AMBIENT						
Model Number	Suction Temperature (SST)					
	30°F	25°F	20°F	10°F	0°F	-10°F
AS*R9440Z*****	3616	3226	3012	2310	1713	1219
AS*R9460Z*****	5486	4866	4523	3456	2594	1936
AS*R9480Z*****	7117	6422	6072	4794	3690	2754

*All capacity data is at dew point conditions

*Return gas 40°F below 20°F Evaporator and 65°F above 20°F evaporator, Sub Cooling 5°F

*Medium temperature evaporating temperature range is from -10°F to +45°F