



tecumseh

C O N D E N S I N G U N I T

argus
by tecumseh



engineered for next-gen refrigeration



flexible

wide range of reciprocating
and scroll models with
multi-refrigerant compatibility



improved design

product enhancements for
service maintenance and
safety compliance



designed to match
seamlessly designed
for new and existing
installations

REFRIGERANTS



APPLICATIONS

walk-in cold room
freezer room
cold storage
food processing



TABLE OF CONTENTS

nomenclature.....	2
pre-configured feature sets.....	3
cooling performance.....	4
electrical specifications.....	18
technical specifications.....	20
chassis size.....	22

NOMENCLATURE

1	2	3	4	5	6
AS	H	R	9	440	P
CU family	product type	compressor	application range	nominal capacity	refrigerant
AS	H - outdoor - remote N - indoor - remote	S - scroll R - reciprocating	9 - medium 2 - low	First number is total digits. Remainder is capacity in BTU/h. This example : 4,000 BTU/h	A1 refrigerants R-404A R-448A R-449A A2L refrigerants R-455A R-454A R-454C P = A1 + A2L Z = A1 only

7	8	9	10
NA	H	P	1
power supply	unit configuration (application)	factory installed options	generation
AA - 115V/60Hz/1 NA - 208-230V/60Hz/1 FA - 208-230V/60Hz/3	F - tube and fin with PSC fan motor H - tube and fin with high efficiency, EC fan motor	P - Platinum G - Gold C - Custom	1 - 1 st





PRE-CONFIGURED FEATURE SETS

features	LOW BACK PRESSURE (LBP)		MEDIUM BACK PRESSURE (MBP)	
	platinum	gold	platinum	gold
service valves	X	X	X	X
crankcase heater	X	X	X	X
adjustable low pressure control	X	X	X	X
fixed low pressure switch				
High pressure switch	X	X	X	X
receiver tank	X		X	
receiver tank (heated and insulated)		X		X*
liquid line filter drier	X	X	X	X
sight glass	X	X	X	X
discharge check valve	X	X		X
accumulator (insulated)	X	X		X
suction line filter		X		X
head pressure control	X	X	X	X
electromechanical defrost timer		X		X
electrical box	X	X	X	X
led light	X	X	X	X
QR code	X	X	X	X
access door (removable)	X	X	X	X
pre-painted enclosure	X	X	X	X



COOLING PERFORMANCE

R-455A - LOW BACK PRESSURE (LBP)

model	compressor type	AWEF rating	ASHRAE return gas evaporator 40°F / sub cooling 5°F					
			ambient (°F)	evaporating temperature (°F)				
				-40	-30	-20	-10	0
ASHR2430P*****	Reciprocating	2.8	80	1,789	2,453	3,265	4,237	5,378
			90	1,519	2,109	2,830	3,696	4,716
			100	1,273	1,792	2,425	3,188	4,091
			110	1,051	1,502	2,052	2,715	3,505
ASHR2440P*****	Reciprocating	2.8	80	2,093	2,873	3,824	4,958	6,271
			90	1,777	2,469	3,316	4,330	5,510
			100	1,487	2,096	2,842	3,738	4,790
			110	1,226	1,755	2,404	3,188	4,114
ASHR2460P*****	Reciprocating	2.8	80	2,211	3,552	5,129	6,942	8,967
			90	1,699	2,959	4,436	6,132	8,028
			100	1,197	2,378	3,756	5,335	7,105
			110	709	1,812	3,091	4,556	6,198
ASHR2480P*****	Reciprocating	2.8	80	3,450	5,529	8,097	11,193	14,824
			90	2,667	4,594	6,971	9,843	13,226
			100	1,925	3,704	5,896	8,548	11,686
			110	1,234	2,871	4,884	7,324	10,223
ASHS2480P*****	Scroll	2.8	80	5,047	6,347	8,000	10,042	12,523
			90	4,657	5,910	7,470	9,375	11,675
			100	4,263	5,468	6,936	8,705	10,824
			110	3,874	5,031	6,407	8,040	9,982
ASHR2510P*****	Reciprocating	2.8	80	4,568	6,642	9,224	12,355	16,042
			90	3,813	5,720	8,100	11,000	14,434
			100	3,079	4,818	6,995	9,662	12,842
			110	2,374	3,945	5,917	8,350	11,273
ASHS2510P*****	Scroll	2.8	80	6,347	7,977	10,081	12,692	15,831
			90	5,857	7,424	9,410	11,850	14,768
			100	5,363	6,865	8,733	11,002	13,699
			110	4,875	6,312	8,062	10,161	12,639
ASHS2512P*****	Scroll	2.8	80	7,046	8,866	11,196	14,056	17,435
			90	6,502	8,252	10,454	13,127	16,266
			100	5,952	7,631	9,702	12,189	15,089
			110	5,408	7,015	8,955	11,255	13,917
ASHS2514P*****	Scroll	2.8	80	8,979	11,273	14,145	17,598	21,610
			90	8,284	10,488	13,193	16,409	20,119
			100	7,576	9,687	12,224	15,201	18,612
			110	6,867	8,884	11,253	13,991	17,101



COOLING PERFORMANCE

R-455A - LOW BACK PRESSURE (LBP)

model	compressor type	AWEF rating	ASHRAE return gas evaporator 40°F / sub cooling 5°F					
			ambient (°F)	evaporating temperature (°F)				
				-40	-30	-20	-10	0
ASHS2520P*****	Scroll	2.8	80	12,855	16,157	20,418	25,705	32,062
			90	11,862	15,036	19,059	24,001	29,909
			100	10,861	13,904	17,687	22,283	27,745
			110	9,873	12,784	16,328	20,579	25,596
ASHS2524P*****	Scroll	2.8	80	15,316	19,275	24,308	30,449	37,672
			90	14,134	17,942	22,694	28,430	35,135
			100	12,938	16,590	21,059	26,390	32,578
			110	11,751	15,244	19,429	24,355	30,028

R-455A - MEDIUM BACK PRESSURE (MBP)

model	compressor type	AWEF rating	ASHRAE ≤ 20°F : 40°F return gas > 20°F : 65°F return gas sub cooling 5°F					
			ambient (°F)	evaporating temperature (°F)				
				0	10	20	30	40
ASHR9460P*****	Reciprocating	7.6	80	4,908	6,335	7,822	9,372	11,007
			90	4,488	5,812	7,191	8,636	10,171
			100	4,009	5,253	6,548	7,910	9,364
			110	3,501	4,685	5,916	7,212	8,600
ASHR9480P*****	Reciprocating	7.6	80	5,851	7,269	8,838	10,563	12,447
			90	5,353	6,704	8,179	9,787	11,531
			100	4,862	6,145	7,528	9,019	10,625
			110	4,380	5,595	6,886	8,262	9,731
ASHR9510P*****	Reciprocating	7.6	80	5,127	7,222	9,673	12,536	15,870
			90	4,325	6,246	8,474	11,073	14,104
			100	3,571	5,325	7,337	9,674	12,406
			110	2,879	4,471	6,274	8,355	10,791
ASHR9512P*****	Reciprocating	7.6	80	7,760	10,772	14,154	17,906	22,008
			90	6,508	9,317	12,443	15,897	19,671
			100	5,299	7,909	10,785	13,949	17,401
			110	4,149	6,564	9,196	12,074	15,208
ASHS9516P*****	Scroll	7.6	80	12,408	15,292	18,568	22,275	26,454
			90	11,525	14,242	17,322	20,810	24,752
			100	10,559	13,113	16,002	19,274	22,983
			110	9,492	11,889	14,590	17,652	21,137



COOLING PERFORMANCE

R-455A - MEDIUM BACK PRESSURE (MBP)

model	compressor type	AWEF rating	ASHRAE ≤ 20°F : 40°F return gas > 20°F : 65°F return gas sub cooling 5°F					
			ambient (°F)	evaporating temperature (°F)				
				0	10	20	30	40
ASHS9520P*****	Scroll	7.6	80	15,295	18,754	22,684	27,119	32,076
			90	14,159	17,407	21,094	25,259	29,927
			100	12,916	15,956	19,405	23,305	27,692
			110	11,542	14,382	17,600	21,248	25,368
ASHS9522P*****	Scroll	7.6	80	16,772	20,531	24,787	29,571	34,899
			90	15,500	19,025	23,012	27,499	32,511
			100	14,105	17,400	21,124	25,322	30,028
			110	12,566	15,639	19,109	23,030	27,450
ASHS9524P*****	Scroll	7.6	80	21,976	27,050	32,822	39,360	46,727
			90	20,399	25,178	30,606	36,760	43,714
			100	18,674	23,164	28,255	34,032	40,582
			110	16,766	20,977	25,741	31,154	37,317
ASHS9532P*****	Scroll	7.6	80	25,304	31,059	37,607	45,004	53,283
			90	23,435	28,846	34,998	41,954	49,760
			100	21,388	26,463	32,226	38,752	46,099
			110	19,126	23,876	29,266	35,380	42,292
ASHS9540P*****	Scroll	7.6	80	30,991	38,032	46,038	55,076	65,184
			90	28,687	35,306	42,826	51,323	60,854
			100	26,162	32,368	39,412	47,384	56,353
			110	23,370	29,179	35,766	43,235	51,674
ASHS9548P*****	Scroll	7.6	80	36,167	44,251	53,381	63,618	74,992
			90	33,398	40,984	49,545	59,156	69,867
			100	30,361	37,461	45,467	54,470	64,544
			110	27,008	33,642	41,117	49,544	59,023



COOLING PERFORMANCE

R-454C - LOW BACK PRESSURE (LBP)

model	compressor type	AWEF rating	ASHRAE return gas evaporator 40°F / sub cooling 5°F					
			ambient (°F)	evaporating temperature (°F)				
				-40	-30	-20	-10	0
ASHR2430P*****	Reciprocating	2.8	80	1,686	2,320	3,094	4,018	5,093
			90	1,437	2,004	2,695	3,523	4,491
			100	1,206	1,708	2,320	3,055	3,917
			110	995	1,435	1,971	2,616	3,376
ASHR2440P*****	Reciprocating	2.8	80	1,779	2,450	3,265	4,233	5,353
			90	1,515	2,116	2,846	3,715	4,724
			100	1,270	1,804	2,451	3,224	4,125
			110	1,048	1,516	2,084	2,763	3,559
ASHS2480P*****	Scroll	2.8	80	4,586	5,716	7,196	9,058	11,335
			90	4,244	5,347	6,757	8,507	10,632
			100	3,894	4,966	6,305	7,942	9,914
			110	3,543	4,583	5,848	7,372	9,189
ASHR2510P*****	Reciprocating	2.8	80	3,806	5,706	8,062	10,917	14,283
			90	3,138	4,921	7,126	9,796	12,950
			100	2,457	4,117	6,165	8,648	11,588
			110	1,776	3,307	5,193	7,485	10,209
ASHS2510P*****	Scroll	2.8	80	5,776	7,202	9,075	11,418	14,237
			90	5,347	6,737	8,522	10,726	13,359
			100	4,906	6,255	7,950	10,015	12,460
			110	4,462	5,769	7,370	9,293	11,550
ASHS2512P*****	Scroll	2.8	80	6,414	8,000	10,063	12,622	15,680
			90	5,938	7,483	9,447	11,853	14,703
			100	5,447	6,948	8,810	11,059	13,700
			110	4,951	6,404	8,162	10,251	12,683
ASHS2514P*****	Scroll	2.8	80	8,114	10,080	12,616	15,733	19,419
			90	7,496	9,410	11,822	14,744	18,172
			100	6,852	8,712	10,996	13,721	16,891
			110	6,196	7,997	10,151	12,677	15,587
ASHS2520P*****	Scroll	2.8	80	11,665	14,544	18,324	23,056	28,757
			90	10,798	13,603	17,207	21,660	26,985
			100	9,907	12,631	16,052	20,223	25,169
			110	9,011	11,649	14,882	18,765	23,331
ASHS2524P*****	Scroll	2.8	80	13,894	17,316	21,749	27,235	33,776
			90	12,856	16,189	20,410	25,563	31,659
			100	11,776	15,014	19,016	23,832	29,480
			110	10,678	13,813	17,590	22,062	27,260



COOLING PERFORMANCE

R-454C - MEDIUM BACK PRESSURE (MBP)

model	compressor type	AWEF rating	ASHRAE ≤ 20°F : 40°F return gas > 20°F : 65°F return gas sub cooling 5°F					
			ambient (°F)	evaporating temperature (°F)				
				0	10	20	30	40
ASHR9460P*****	Reciprocating	7.6	80	4,491	5,627	6,883	8,275	9,816
			90	4,136	5,212	6,391	7,691	9,128
			100	3,766	4,787	5,895	7,110	8,448
			110	3,384	4,356	5,400	6,534	7,778
ASHR9480P*****	Reciprocating	7.6	80	5,272	6,575	8,041	9,672	11,464
			90	4,831	6,075	7,456	8,980	10,645
			100	4,394	5,577	6,874	8,291	9,829
			110	3,961	5,083	6,295	7,605	9,017
ASHR9510P*****	Reciprocating	7.6	80	4,329	6,128	8,232	10,685	13,531
			90	3,656	5,316	7,240	9,476	12,072
			100	3,025	4,551	6,301	8,324	10,673
			110	2,445	3,844	5,424	7,238	9,344
ASHR9512P*****	Reciprocating	7.6	80	6,666	9,280	12,240	15,555	19,218
			90	5,603	8,056	10,807	13,871	17,248
			100	4,574	6,871	9,420	12,241	15,339
			110	3,589	5,735	8,087	10,670	13,497
ASHS9516P*****	Scroll	7.6	80	10,804	13,303	16,148	19,366	22,974
			90	10,047	12,399	15,072	18,096	21,494
			100	9,208	11,412	13,915	16,748	19,940
			110	8,265	10,327	12,663	15,311	18,307
ASHS9520P*****	Scroll	7.6	80	13,751	16,956	20,618	24,775	29,452
			90	12,808	15,828	19,273	23,185	27,595
			100	11,763	14,599	17,829	21,499	25,646
			110	10,589	13,246	16,266	19,700	23,594
ASHS9522P*****	Scroll	7.6	80	15,106	18,599	22,577	27,077	32,122
			90	14,048	17,335	21,072	25,301	30,052
			100	12,873	15,956	19,455	23,416	27,879
			110	11,556	14,439	17,704	21,407	25,595
ASHS9524P*****	Scroll	7.6	80	19,623	24,269	29,608	35,705	42,603
			90	18,320	22,710	27,747	33,500	40,022
			100	16,881	21,017	25,755	31,169	37,319
			110	15,264	19,154	23,600	28,683	34,472
ASHS9532P*****	Scroll	7.6	80	22,626	27,923	33,983	40,866	48,617
			90	21,081	26,078	31,785	38,271	45,588
			100	19,369	24,070	29,429	35,522	42,412
			110	17,448	21,860	26,879	32,591	39,071



COOLING PERFORMANCE

R-454C - MEDIUM BACK PRESSURE (MBP)

model	compressor type	AWEF rating	ASHRAE ≤ 20°F : 40°F return gas > 20°F : 65°F return gas sub cooling 5°F					
			ambient (°F)	evaporating temperature (°F)				
				0	10	20	30	40
ASHS9540P*****	Scroll	7.6	80	27,754	34,253	41,683	50,123	59,625
			90	25,852	31,982	38,980	46,932	55,901
			100	23,742	29,508	36,079	43,549	51,995
			110	21,371	26,783	32,938	39,941	47,884
ASHS9548P*****	Scroll	7.6	80	32,451	39,933	48,431	58,018	68,737
			90	30,153	37,197	45,185	54,201	64,305
			100	27,601	34,214	41,699	50,154	59,659
			110	24,739	30,933	37,931	45,849	54,787

R-454A - LOW BACK PRESSURE (LBP)

model	compressor type	AWEF rating	ASHRAE return gas evaporator 40°F / sub cooling 5°F					
			ambient (°F)	evaporating temperature (°F)				
				-40	-30	-20	-10	0
ASHS2480P*****	Scroll	2.8	80	5,260	6,520	8,183	10,271	12,793
			90	4,878	6,118	7,712	9,684	12,045
			100	4,479	5,694	7,217	9,071	11,269
			110	4,071	5,259	6,707	8,441	10,475
ASHS2510P*****	Scroll	2.8	80	6,549	8,125	10,196	12,783	15,891
			90	6,075	7,620	9,600	12,037	14,940
			100	5,582	7,091	8,976	11,261	13,957
			110	5,081	6,550	8,337	10,467	12,955
ASHS2512P*****	Scroll	2.8	80	7,258	8,990	11,260	14,088	17,473
			90	6,723	8,421	10,591	13,253	16,412
			100	6,163	7,823	9,889	12,383	15,315
			110	5,591	7,209	9,167	11,491	14,195
ASHS2514P*****	Scroll	2.8	80	8,991	11,135	13,927	17,377	21,471
			90	8,308	10,408	13,073	16,314	20,126
			100	7,595	9,648	12,181	15,211	18,740
			110	6,870	8,869	11,266	14,082	17,326
ASHS2520P*****	Scroll	2.8	80	13,101	16,253	20,399	25,587	31,829
			90	12,135	15,228	19,194	24,084	29,918
			100	11,121	14,147	17,926	22,513	27,935
			110	10,082	13,032	16,617	20,895	25,903
ASHS2524P*****	Scroll	2.8	80	15,464	19,179	24,038	30,083	37,311
			90	14,298	17,943	22,590	28,282	35,029
			100	13,080	16,647	21,073	26,407	32,671
			110	11,838	15,317	19,513	24,484	30,260



COOLING PERFORMANCE

R-454A - MEDIUM BACK PRESSURE (MBP)

model	compressor type	AWEF rating	ASHRAE ≤ 20°F : 40°F return gas > 20°F : 65°F return gas sub cooling 5°F					
			ambient (°F)	evaporating temperature (°F)				
				0	10	20	30	40
ASHS9516P*****	Scroll	7.6	80	12,524	15,499	18,915	22,811	27,217
			90	11,719	14,530	17,753	21,429	25,593
			100	10,825	13,475	16,505	19,964	23,891
			110	9,818	12,308	15,152	18,400	22,098
ASHS9520P*****	Scroll	7.6	80	15,477	19,095	23,221	27,893	33,140
			90	14,438	17,848	21,730	26,128	31,076
			100	13,279	16,483	20,123	24,250	28,908
			110	11,972	14,975	18,380	22,246	26,630
ASHS9522P*****	Scroll	7.6	80	17,007	20,952	25,435	30,495	36,157
			90	15,839	19,553	23,765	28,521	33,855
			100	14,536	18,020	21,963	26,421	31,436
			110	13,065	16,324	20,008	24,179	28,899
ASHS9524P*****	Scroll	7.6	80	22,223	27,499	33,550	40,444	48,229
			90	20,778	25,766	31,475	37,982	45,343
			100	19,172	23,874	29,246	35,370	42,315
			110	17,358	21,782	26,826	32,580	39,127
ASHS9532P*****	Scroll	7.6	80	25,655	31,683	38,566	46,371	55,145
			90	23,941	29,630	36,114	43,469	51,755
			100	22,029	27,383	33,473	40,386	48,195
			110	19,870	24,898	30,606	37,094	44,453
ASHS9540P*****	Scroll	7.6	80	31,433	38,813	47,233	56,776	67,496
			90	29,318	36,282	44,212	53,203	63,325
			100	26,958	33,510	40,957	49,406	58,944
			110	24,291	30,444	37,423	45,352	54,340
ASHS9548P*****	Scroll	7.6	80	36,764	45,264	54,897	65,740	77,838
			90	34,206	42,211	51,265	61,462	72,870
			100	31,347	38,862	47,348	56,915	67,659
			110	28,122	35,163	43,102	52,073	62,209



COOLING PERFORMANCE

R-448A/R-449A - LOW BACK PRESSURE (LBP)

model	compressor type	AWEF rating	ASHRAE return gas evaporator 40°F / sub cooling 5°F					
			ambient (°F)	evaporating temperature (°F)				
				-40	-30	-20	-10	0
ASHR2430P*****	Reciprocating	2.8	80	-	1,447	1,821	2,210	3,036
			90	-	1,142	1,895	2,712	3,591
			100	-	837	1,581	2,388	3,257
			110	-	532	1,267	2,064	2,924
ASHR2440P*****	Reciprocating	2.8	80	-	1,619	2,360	3,306	4,445
			90	-	1,371	2,037	2,900	3,960
			100	-	1,124	1,710	2,494	3,474
			110	-	876	1,438	2,172	3,109
ASHR2460P*****	Reciprocating	2.8	80	2,289	3,547	5,061	6,838	8,875
			90	1,843	3,032	4,458	6,126	8,036
			100	1,398	2,517	3,853	5,414	7,197
			110	961	2,007	3,252	4,705	6,363
ASHR2480P*****	Reciprocating	2.8	80	3,465	5,432	7,879	10,839	14,327
			90	2,781	4,626	6,918	9,693	12,968
			100	2,103	3,822	5,956	8,543	11,605
			110	1,439	3,028	5,000	7,398	10,244
ASHS2480P*****	Scroll	2.8	80	5,005	6,392	8,094	10,159	12,627
			90	4,712	6,048	7,657	9,590	11,888
			100	4,389	5,677	7,197	9,001	11,132
			110	4,024	5,269	6,704	8,383	10,350
ASHR2510P*****	Reciprocating	2.8	80	4,343	6,777	9,749	13,289	17,403
			90	3,489	5,784	8,577	11,900	15,762
			100	2,641	4,792	7,404	10,510	14,121
			110	1,810	3,812	6,241	9,129	12,490
ASHS2510P*****	Scroll	2.8	80	6,311	8,049	10,154	12,674	15,649
			90	5,940	7,614	9,600	11,954	14,716
			100	5,528	7,141	9,014	11,203	13,754
			110	5,061	6,617	8,379	10,408	12,751
ASHS2512P*****	Scroll	2.8	80	6,986	8,893	11,199	13,957	17,202
			90	6,568	8,404	10,581	13,154	16,166
			100	6,102	7,871	9,922	12,315	15,096
			110	5,571	7,277	9,208	11,424	13,977
ASHS2514P*****	Scroll	2.8	80	8,414	10,834	13,621	16,869	20,655
			90	7,834	10,160	12,790	15,821	19,333
			100	7,224	9,433	11,887	14,683	17,905
			110	6,618	8,686	10,940	13,481	16,394
ASHS2520P*****	Scroll	2.8	80	12,235	15,798	19,941	24,826	30,595
			90	11,422	14,859	18,789	23,377	28,765
			100	10,555	13,830	17,517	21,779	26,764
			110	9,680	12,759	16,168	20,074	24,631



COOLING PERFORMANCE

R-448A/R-449A - LOW BACK PRESSURE (LBP)

model	compressor type	AWEF rating	ASHRAE return gas evaporator 40°F / sub cooling 5°F					
			ambient (°F)	evaporating temperature (°F)				
				-40	-30	-20	-10	0
ASHS2524P*****	Scroll	2.8	80	14,347	18,508	23,323	28,973	35,609
			90	13,371	17,379	21,940	27,234	33,418
			100	12,339	16,156	20,426	25,334	31,040
			110	11,308	14,891	18,832	23,318	28,515
ASHS2527ZFAPFI	Scroll	2.8	80	-	17,557	22,672	28,653	35,634
			90	-	17,026	21,722	27,225	33,498
			100	-	16,324	20,543	25,553	31,533
			110	-	15,464	19,245	23,802	29,313
ASHS2531ZFAPFI	Scroll	2.8	80	-	20,493	26,485	33,257	41,068
			90	-	19,829	25,223	31,561	38,797
			100	-	18,968	23,811	29,580	36,223
			110	-	17,922	22,262	27,508	33,870
ASHS2542ZFAPFI	Scroll	2.8	80	-	26,565	34,662	44,039	54,971
			90	-	25,739	33,033	41,582	51,661
			100	-	24,650	31,394	39,250	48,274
			110	-	23,313	29,396	36,542	45,172

R-448A/R-449A - MEDIUM BACK PRESSURE (MBP)

model	compressor type	AWEF rating	ASHRAE ≤ 20°F : 40°F return gas > 20°F : 65°F return gas sub cooling 5°F					
			ambient (°F)	evaporating temperature (°F)				
				0	10	20	30	40
ASHR9460P*****	Reciprocating	7.6	80	-	3,552	4,811	6,279	7,542
			90	-	3,111	4,248	5,593	6,774
			100	-	2,671	3,685	4,907	6,005
			110	-	2,230	3,123	4,220	5,237
ASHR9480P*****	Reciprocating	7.6	80	-	4,741	6,131	7,739	9,068
			90	-	4,260	5,551	7,059	8,329
			100	-	3,777	4,971	6,380	7,590
			110	-	3,296	4,391	5,701	6,851
ASHR9510P*****	Reciprocating	7.6	80	5,166	7,187	9,508	12,157	15,149
			90	4,459	6,393	8,586	11,069	13,860
			100	3,733	5,574	7,635	9,950	12,539
			110	3,005	4,746	6,670	8,813	11,200
ASHR9512P*****	Reciprocating	7.6	80	7,597	10,420	13,646	17,284	21,333
			90	6,508	9,153	12,148	15,509	19,239
			100	5,444	7,919	10,690	13,780	17,198
			110	4,415	6,726	9,280	12,104	15,215



COOLING PERFORMANCE

R-448A/R-449A - MEDIUM BACK PRESSURE (MBP)

model	compressor type	AWEF rating	ASHRAE ≤ 20°F : 40°F return gas > 20°F : 65°F return gas sub cooling 5°F					
			ambient (°F)	evaporating temperature (°F)				
				0	10	20	30	40
ASHS9516P*****	Scroll	7.6	80	12,530	15,465	18,837	22,665	26,959
			90	11,739	14,469	17,604	21,166	25,171
			100	10,953	13,463	16,345	19,628	23,335
			110	10,199	12,471	15,084	18,076	21,474
ASHS9520P*****	Scroll	7.6	80	15,476	19,024	23,066	27,614	32,668
			90	14,483	17,771	21,511	25,724	30,421
			100	13,507	16,515	19,937	23,801	28,130
			110	12,579	15,286	18,372	21,873	25,824
ASHS9522P*****	Scroll	7.6	80	16,984	20,831	25,192	30,076	35,477
			90	15,886	19,443	23,469	27,983	32,991
			100	14,813	18,059	21,733	25,862	30,468
			110	13,798	16,712	20,015	23,745	27,941
ASHS9524P*****	Scroll	7.6	80	21,751	26,851	32,711	39,366	46,830
			90	20,370	25,114	30,561	36,753	43,717
			100	19,004	23,362	28,369	34,076	40,521
			110	17,692	21,635	26,174	31,373	37,284
ASHS9532P*****	Scroll	7.6	80	25,082	30,879	37,501	44,975	53,306
			90	23,474	28,851	34,987	41,921	49,674
			100	21,892	26,816	32,438	38,808	45,965
			110	20,384	24,823	29,900	35,683	42,226
ASHS9540P*****	Scroll	7.6	80	30,764	37,870	45,985	55,144	65,349
			90	28,787	35,377	42,895	51,389	60,884
			100	26,845	32,877	39,762	47,563	56,326
			110	24,995	30,429	36,645	43,723	51,732
ASHS9548P*****	Scroll	7.6	80	35,674	43,751	52,902	63,145	74,465
			90	33,362	40,828	49,277	58,746	69,248
			100	31,109	37,920	45,628	54,293	63,957
			110	28,983	35,094	42,024	49,855	58,666
ASHS9563ZFAFPI	Scroll	7.6	80	44,649	55,000	67,150	80,928	-
			90	42,498	51,948	63,272	76,016	-
			100	39,713	48,883	59,066	71,349	-
			110	36,419	45,036	54,919	66,375	-
ASHS9575ZFAFPI	Scroll	7.6	80	54,306	66,496	80,644	97,060	-
			90	51,250	62,621	76,241	91,528	-
			100	48,041	58,711	70,928	85,004	-
			110	43,855	53,791	65,673	78,696	-



COOLING PERFORMANCE

R-448A/R-449A - MEDIUM BACK PRESSURE (MBP)

model	compressor type	AWEF rating	ASHRAE ≤ 20°F : 40°F return gas > 20°F : 65°F return gas sub cooling 5°F					
			ambient (°F)	evaporating temperature (°F)				
				0	10	20	30	40
ASHS9583ZFAFP1	Scroll	7.6	80	60,563	74,115	89,823	107,355	-
			90	57,008	70,116	84,196	101,011	-
			100	53,267	65,125	78,677	94,274	-
			110	48,913	60,032	72,626	87,048	-
ASHS9593ZFAFP1	Scroll	7.6	80	68,913	83,791	101,458	121,126	-
			90	64,689	79,025	95,506	113,689	-
			100	60,238	73,687	89,030	105,763	-
			110	55,056	67,666	81,084	97,235	-

R-404A - LOW BACK PRESSURE (LBP)

model	compressor type	AWEF rating	ASHRAE return gas evaporator 40°F / sub cooling 5°F					
			ambient (°F)	evaporating temperature (°F)				
				-40	-30	-20	-10	0
ASHR2430P*****	Reciprocating	2.8	80	-	1,926	2,794	3,750	4,795
			90	-	1,528	2,190	3,080	4,215
			100	-	1,131	1,877	2,374	3,237
			110	-	734	1,419	2,192	3,054
ASHR2440P*****	Reciprocating	2.8	80	-	2,209	3,190	4,134	5,043
			90	-	1,873	2,821	3,733	4,610
			100	-	1,537	2,453	2,480	3,453
			110	-	1,201	2,084	2,932	3,743
ASHR2460P*****	Reciprocating	2.8	80	2,867	4,124	5,641	7,413	9,427
			90	2,417	3,592	5,000	6,635	8,489
			100	1,976	3,067	4,362	5,859	7,550
			110	1,549	2,551	3,732	5,089	6,617
ASHR2480P*****	Reciprocating	2.8	80	4,443	6,443	8,885	11,781	15,129
			90	3,742	5,614	7,885	10,567	13,662
			100	3,052	4,791	6,886	9,351	12,190
			110	2,383	3,983	5,897	8,140	10,720
ASHS2480P*****	Scroll	2.8	80	5,278	6,714	8,474	10,560	12,964
			90	4,941	6,289	7,930	9,865	12,091
			100	4,574	5,821	7,332	9,109	11,150
			110	4,209	5,343	6,712	8,319	10,166
ASHR2510P*****	Reciprocating	2.8	80	5,416	7,835	10,766	14,209	18,150
			90	4,555	6,819	9,542	12,726	16,362
			100	3,712	5,813	8,322	11,244	14,572
			110	2,895	4,827	7,117	9,771	12,787



COOLING PERFORMANCE

R-404A - LOW BACK PRESSURE (LBP)

model	compressor type	AWEF rating	ASHRAE return gas evaporator 40°F / sub cooling 5°F					
			ambient (°F)	evaporating temperature (°F)				
				-40	-30	-20	-10	0
ASHS2510P*****	Scroll	2.8	80	6,581	8,354	10,514	13,054	15,957
			90	6,147	7,805	9,811	12,158	14,835
			100	5,683	7,213	9,052	11,197	13,640
			110	5,229	6,615	8,274	10,205	12,402
ASHS2512P*****	Scroll	2.8	80	7,258	9,203	11,566	14,331	17,478
			90	6,772	8,588	10,777	13,327	16,222
			100	6,257	7,929	9,931	12,257	14,892
			110	5,756	7,267	9,070	11,157	13,520
ASHS2514P*****	Scroll	2.8	80	8,896	11,248	14,079	17,357	21,047
			90	8,277	10,463	13,073	16,081	19,457
			100	7,634	9,637	12,013	14,740	17,793
			110	7,022	8,824	10,948	13,379	16,096
ASHS2520P*****	Scroll	2.8	80	13,012	16,530	20,819	25,865	31,642
			90	12,144	15,434	19,416	24,082	29,411
			100	11,219	14,252	17,904	22,169	27,032
			110	10,317	13,062	16,354	20,192	24,568
ASHS2524P*****	Scroll	2.8	80	15,230	19,315	24,268	30,058	36,639
			90	14,192	18,002	22,587	27,924	33,974
			100	13,098	16,601	20,793	25,654	31,155
			110	12,043	15,203	18,968	23,324	28,251
ASHS2527ZFAFPI	Scroll	2.8	80	-	19,468	24,148	29,913	36,692
			90	-	18,282	22,724	28,149	34,453
			100	-	17,000	21,124	26,131	32,155
			110	-	15,684	19,586	24,149	29,637
ASHS2531ZFAFPI	Scroll	2.8	80	-	22,578	28,021	34,514	42,563
			90	-	21,158	26,303	32,578	39,852
			100	-	19,793	24,591	30,412	37,094
			110	-	18,249	22,572	27,800	34,089
ASHS2542ZFAFPI	Scroll	2.8	80	-	29,664	37,136	46,136	56,735
			90	-	28,015	34,957	43,443	53,680
			100	-	26,033	32,495	40,343	49,785
			110	-	23,990	30,118	37,287	45,909



COOLING PERFORMANCE

R-404A - MEDIUM BACK PRESSURE (MBP)

model	compressor type	AWEF rating	ASHRAE ≤ 20°F : 40°F return gas > 20°F : 65°F return gas sub cooling 5°F					
			ambient (°F)	evaporating temperature (°F)				
				0	10	20	30	40
ASHR9460P*****	Reciprocating	7.6	80	-	4,626	5,968	7,485	8,664
			90	-	4,138	5,345	6,723	7,813
			100	-	3,652	4,722	5,962	6,962
			110	-	3,166	4,099	5,201	6,112
ASHR9480P*****	Reciprocating	7.6	80	-	6,026	7,664	9,449	10,744
			90	-	5,446	6,934	8,568	9,768
			100	-	4,867	6,205	7,687	8,792
			110	-	4,287	5,476	6,806	7,816
ASHR9510P*****	Reciprocating	7.6	80	5,866	7,863	10,147	12,738	15,646
			90	5,124	7,036	9,185	11,591	14,269
			100	4,359	6,177	8,181	10,395	12,837
			110	3,586	5,300	7,151	9,166	11,366
ASHR9512P*****	Reciprocating	7.6	80	8,510	11,332	14,538	18,125	22,076
			90	7,320	9,957	12,910	16,182	19,766
			100	6,162	8,618	11,321	14,280	17,497
			110	5,043	7,320	9,775	12,423	15,275
ASHS9516P*****	Scroll	7.6	80	12,797	15,573	18,739	22,306	26,278
			90	12,000	14,560	17,461	20,724	24,361
			100	11,159	13,497	16,130	19,086	22,385
			110	10,243	12,356	14,721	17,370	20,336
ASHS9520P*****	Scroll	7.6	80	15,769	19,091	22,830	26,988	31,558
			90	14,756	17,805	21,215	24,998	29,161
			100	13,674	16,444	19,521	22,927	26,686
			110	12,488	14,977	17,721	20,757	24,123
ASHS9522P*****	Scroll	7.6	80	17,286	20,869	24,874	29,297	34,125
			90	16,155	19,435	23,077	27,088	31,474
			100	14,940	17,910	21,185	24,785	28,736
			110	13,604	16,264	19,174	22,373	25,906
ASHS9524P*****	Scroll	7.6	80	22,562	27,447	33,009	39,269	46,232
			90	21,154	25,657	30,756	36,483	42,859
			100	19,664	23,777	28,406	33,595	39,382
			110	18,040	21,760	25,918	30,572	35,779
ASHS9532P*****	Scroll	7.6	80	25,989	31,507	37,737	44,686	52,349
			90	24,333	29,406	35,099	41,436	48,431
			100	22,568	27,187	32,336	38,057	44,386
			110	20,635	24,797	29,403	34,515	40,197
ASHS9540P*****	Scroll	7.6	80	31,827	38,561	46,153	54,609	63,920
			90	29,788	35,976	42,909	50,615	59,111
			100	27,612	33,242	39,508	46,461	54,146
			110	25,227	30,296	35,898	42,109	49,006



COOLING PERFORMANCE

R-404A - MEDIUM BACK PRESSURE (MBP)

model	compressor type	AWEF rating	ASHRAE ≤ 20°F : 40°F return gas > 20°F : 65°F return gas sub cooling 5°F					
			ambient (°F)	evaporating temperature (°F)				
				0	10	20	30	40
ASHS9548P*****	Scroll	7.6	80	36,853	44,454	52,930	62,267	72,437
			90	34,425	41,383	49,091	57,562	66,807
			100	31,813	38,116	45,049	52,658	60,995
			110	28,937	34,586	40,755	47,526	55,001
ASHS9563ZFAPPI	Scroll	7.6	80	47,776	58,354	70,652	84,205	-
			90	44,939	54,696	65,435	78,261	-
			100	41,627	50,447	60,546	72,108	-
			110	38,397	46,351	55,373	65,650	-
ASHS9575ZFAPPI	Scroll	7.6	80	57,937	70,217	84,272	100,243	-
			90	54,048	65,667	78,431	92,840	-
			100	50,296	60,350	72,320	85,128	-
			110	46,245	55,182	65,822	76,987	-
ASHS9583ZFAPPI	Scroll	7.6	80	64,434	78,020	93,541	110,236	-
			90	60,440	72,853	86,902	101,791	-
			100	55,711	67,397	79,929	93,958	-
			110	51,047	61,519	72,489	84,656	-
ASHS9593ZFAPPI	Scroll	7.6	80	73,129	87,811	105,110	123,633	-
			90	67,952	81,772	97,360	113,782	-
			100	62,950	75,351	89,176	104,608	-
			110	57,462	68,391	81,410	93,674	-



ELECTRICAL SPECIFICATIONS

LOW BACK PRESSURE (LBP)

model number	platinum item code	gold item code	HP	voltage	compressor electricals		condensing unit data		fan motor			
					RLA	LRA	MCA*	MOPD**	fan type	number of fans	HP***	RLA
ASHR2430PNAHP1	2JH705-PF	2JH705-GF	0.75	208-230V/60Hz/1	3.7	26.5	5.6	15	EC	1	107 W	0.77
ASHR2440PNAH*1	2JH1014-PF	2JH1014-GF	1	208-230V/60Hz/1	4.0	26.5	6.0	15	EC	1	107 W	0.77
ASHR2460PFAH*1	2JH3210-PF	2JH3210-GF	1.5	208-230V/60Hz/3	6.5	50.0	9.1	15	EC	1	107 W	0.77
ASHR2460PNAH*1	2JH3207-PF	2JH3207-GF	1.5	208-230V/60Hz/1	9.6	56.0	12.9	20	EC	1	107 W	0.77
ASHR2480PFAH*1	2JH2028-PF	2JH2028-GF	2	208-230V/60Hz/3	9.7	63.4	13.9	20	EC	2	107 W	0.77
ASHR2480PNAH*1	2JH2022-PF	2JH2022-GF	2	208-230V/60Hz/1	12.8	73.0	17.7	30	EC	2	107 W	0.77
ASHR2510PFAH*1	2JH2029-PF	2JH2029-GF	2.5	208-230V/60Hz/3	8.5	63.0	12.4	20	EC	2	107 W	0.77
ASHR2510PNAH*1	2JH2023-PF	2JH2023-GF	2.5	208-230V/60Hz/1	14.3	92.0	19.7	30	EC	2	107 W	0.77
ASHS2480PFAH*1	2JH2032-PF	2JH2032-GF	2	208-230V/60Hz/3	6.5	88.0	9.9	15	EC	2	107 W	0.77
ASHS2480PNAH*1	2JH2033-PF	2JH2033-GF	2	208-230V/60Hz/1	7.4	45.5	11.0	15	EC	2	107 W	0.77
ASHS2510PFAH*1	2JH2030-PF	2JH2030-GF	2.5	208-230V/60Hz/3	6.8	88.0	10.3	15	EC	2	107 W	0.77
ASHS2510PNAH*1	2JH2031-PF	2JH2031-GF	2.5	208-230V/60Hz/1	8.3	76.0	12.1	20	EC	2	107 W	0.77
ASHS2512PFAH*1	2JH3015-PF	2JH3015-GF	3	208-230V/60Hz/3	6.9	88.0	10.4	15	EC	2	107 W	0.77
ASHS2512PNAH*1	2JH3014-PF	2JH3014-GF	3	208-230V/60Hz/1	9.2	76.0	13.3	20	EC	2	107 W	0.77
ASHS2514PFAH*1	2JH3013-PF	2JH3013-GF	3.5	208-230V/60Hz/3	8.5	136.0	12.4	20	EC	2	107 W	0.77
ASHS2514PNAH*1	2JH3012-PF	2JH3012-GF	3.5	208-230V/60Hz/1	11.5	76.0	16.1	25	EC	2	107 W	0.77
ASHS2520PFAH*1	2JH5008-PF	2JH5008-GF	5	208-230V/60Hz/3	11.2	136.0	16.0	25	EC	1	400 W	1.8
ASHS2520PNAH*1	2JH5007-PF	2JH5007-GF	5	208-230V/60Hz/1	15.6	140.0	21.5	35	EC	1	400 W	1.8
ASHS2524PFAH*1	2JH6004-PF	2JH6004-GF	6	208-230V/60Hz/3	12.2	167.0	17.3	25	EC	1	400 W	1.8
ASHS2527ZFAP1	2JH7000-PF	-	7	208-230V/60Hz/3	18.7	241.0	32.4	50	PSC	1	1/3	2.2
ASHS2531ZFAP1	2JH8001-PF	-	8	208-230V/60Hz/3	20.1	241.0	36.1	60	PSC	1	1/3	2.2
ASHS2542ZFAP1	2JH10002-PF	-	10,00	208-230V/60Hz/3	25.8	290.0	47.2	80	PSC	2	1/3	2.2

* ampacity

** breaker / fuse

*** all fan motor HP (shaft power) is per fan unit



ELECTRICAL SPECIFICATIONS

MEDIUM BACK PRESSURE (MBP)

model number	platinum item code	gold item code	HP	voltage	compressor electricals		condensing unit data		fan motor			
					RLA	LRA	MCA*	MOPD**	fan type	number of fans	HP***	RLA
ASHR9460PNAH*1	2JH704-PF	2JH704-GF	0.75	208-230V/60Hz/1	6.6	34.0	9.2	15	EC	1	107 W	0.77
ASHR9480PNAH*1	2JH1013-PF	2JH1013-GF	1	208-230V/60Hz/1	7.7	32.0	10.6	15	EC	1	107 W	0.77
ASHR9510PNAH*1	2JH1016-PF	2JH1016-GF	1.25	208-230V/60Hz/1	10.4	52.0	14.8	25	EC	2	107 W	0.77
ASHR9510PFAH*1	2JH1017-PF	2JH1016-GF	1.25	208-230V/60Hz/3	6.5	51.0	9.9	15	EC	2	107 W	0.77
ASHR9512PNAH*1	2JH3208-PF	2JH3208-GF	1.5	208-230V/60Hz/1	12.7	60.0	17.6	30	EC	2	107 W	0.77
ASHR9512PFAH*1	2JH3209-PF	2JH3209-GF	1.5	208-230V/60Hz/3	7.9	50.0	11.6	15	EC	2	107 W	0.77
ASHS9516PNAH*1	2JH2020-PF	2JH2020-GF	2	208-230V/60Hz/1	11.2	76.0	15.8	25	EC	2	107 W	0.77
ASHS9516PFAH*1	2JH2024-PF	2JH2024-GF	2	208-230V/60Hz/3	7.2	88.0	10.8	15	EC	2	107 W	0.77
ASHS9520PNAH*1	2JH2026-PF	2JH2026-GF	2.5	208-230V/60Hz/1	12.2	76.0	17.0	25	EC	2	107 W	0.77
ASHS9520PFAH*1	2JH2027-PF	2JH2027-GF	2.5	208-230V/60Hz/3	8.3	88.0	12.1	20	EC	2	107 W	0.77
ASHS9522PNAH*1	2JH2021-PF	2JH2021-GF	2.75	208-230V/60Hz/1	13.5	76.0	18.6	30	EC	2	107 W	0.77
ASHS9522PFAH*1	2JH2025-PF	2JH2025-GF	2.75	208-230V/60Hz/3	9.0	88.0	13.0	20	EC	2	107 W	0.77
ASHS9524PNAH*1	2JH3010-PF	2JH3010-GF	3	208-230V/60Hz/1	16.1	109.0	22.1	35	EC	1	400 W	1.8
ASHS9524PFAH*1	2JH3011-PF	2JH3011-GF	3	208-230V/60Hz/3	10.8	136.0	15.5	25	EC	1	400 W	1.8
ASHS9532PNAH*1	2JH4003-PF	2JH4003-GF	4	208-230V/60Hz/1	17.8	140.0	24.3	40	EC	1	400 W	1.8
ASHS9532PFAH*1	2JH4004-PF	2JH4004-GF	4	208-230V/60Hz/3	12.4	140.0	17.5	25	EC	1	400 W	1.8
ASHS9540PNAH*1	2JH5005-PF	2JH5005-GF	5	208-230V/60Hz/1	21.3	140.0	28.6	45	EC	1	400 W	1.8
ASHS9540PFAH*1	2JH5006-PF	2JH5006-GF	5	208-230V/60Hz/3	14.8	140.0	20.5	35	EC	1	400 W	1.8
ASHS9548PFAH*1	2JH6003-PF	2JH6003-GF	6	208-230V/60Hz/3	17.2	167.0	23.5	40	EC	1	400 W	1.8
ASHS9563ZFAFPI	2JH8000-PF	-	8	208-230V/60Hz/3	25.3	241.0	36.2	60	PSC	2	1/3	2.2
ASHS9575ZFAFPI	2JH9000-PF	-	9	208-230V/60Hz/3	28.4	241.0	40.1	60	PSC	2	1/3	2.2
ASHS9583ZFAFPI	2JH10001-PF	-	10	208-230V/60Hz/3	32.5	290.0	45.2	70	PSC	2	1/3	2.2
ASHS9593ZFAFPI	2JH12000-PF	-	12	208-230V/60Hz/3	36.4	290.0	50.8	80	PSC	2	1/3	2.2

* ampacity

** breaker / fuse

*** all fan motor HP (shaft power) is per fan unit



TECHNICAL SPECIFICATIONS

LOW BACK PRESSURE (LBP)

model number	platinum item code	gold item code	HP	compressor type	connections		weight (lbs)	pump down capacity (lbs)*	chasis size	refrigerants
					liquid	suction				
ASHR2430PNAHP1	2JH705-PF	2JH705-GF	0.75	reciprocating	3/8	3/8	159	9.50	S	R-454C R-455A
ASHR2440PNAH*1	2JH1014-PF	2JH1014-GF	1.00	reciprocating	3/8	3/8	159	9.50	S	
ASHR2460PFAH*1	2JH3210-PF	2JH3210-GF	1.50	reciprocating	3/8	5/8	159	9.50	S	R-404A R-448A R-449A R-454C R-455A
ASHR2460PNAH*1	2JH3207-PF	2JH3207-GF	1.50	reciprocating	3/8	5/8	159	9.50	S	
ASHR2480PFAH*1	2JH2028-PF	2JH2028-GF	2.00	reciprocating	1/2	5/8	234	22.15	M	
ASHR2480PNAH*1	2JH2022-PF	2JH2022-GF	2.00	reciprocating	1/2	5/8	234	22.15	M	
ASHR2510PFAH*1	2JH2029-PF	2JH2029-GF	2.50	reciprocating	1/2	5/8	234	22.15	M	
ASHR2510PNAH*1	2JH2023-PF	2JH2023-GF	2.50	scroll	1/2	5/8	234	22.15	M	
ASHS2480PFAH*1	2JH2032-PF	2JH2032-GF	2.00	scroll	1/2	7/8	234	22.15	M	
ASHS2480PNAH*1	2JH2033-PF	2JH2033-GF	2.00	scroll	1/2	7/8	234	22.12	M	
ASHS2510PFAH*1	2JH2030-PF	2JH2030-GF	2.50	scroll	1/2	7/8	234	22.12	M	R-404A R-448A R-449A R-454C R-455A R-454A
ASHS2510PNAH*1	2JH2031-PF	2JH2031-GF	2.50	scroll	1/2	7/8	234	22.15	M	
ASHS2512PFAH*1	2JH3015-PF	2JH3015-GF	3.00	scroll	1/2	7/8	234	22.15	M	
ASHS2512PNAH*1	2JH3014-PF	2JH3014-GF	3.00	scroll	1/2	7/8	234	22.15	M	
ASHS2514PFAH*1	2JH3013-PF	2JH3013-GF	3.50	scroll	1/2	7/8	234	22.15	M	
ASHS2514PNAH*1	2JH3012-PF	2JH3012-GF	3.50	scroll	1/2	7/8	234	22.15	M	
ASHS2520PFAH*1	2JH5008-PF	2JH5008-GF	5.00	scroll	1/2	1 1/8	347	40.65	L	
ASHS2520PNAH*1	2JH5007-PF	2JH5007-GF	5.00	scroll	1/2	1 1/8	347	40.65	L	
ASHS2524PFAH*1	2JH6004-PF	2JH6004-GF	6.00	scroll	1/2	1 1/8	347	40.65	L	
ASHS2527ZFAFPI	2JH7000-PF	-	7.00	scroll	1/2	1 1/8	347	42.70	L	
ASHS2531ZFAFPI	2JH8001-PF	-	8.00	scroll	1/2	1 1/8	347	42.70	L	R-404A R-448A R-449A
ASHS2542ZFAFPI	2JH10002-PF	-	10.00	scroll	7/8	1 3/8	480	67.50	XL	

*pumpdown capacity at 32.2°C (90°F) 90%



TECHNICAL SPECIFICATIONS

MEDIUM BACK PRESSURE (MBP)

model number	platinum item code	gold item code	HP	compressor type	connections		weight (lbs)	pump down capacity (lbs)*	chasis size	refrigerants
					liquid	suction				
ASHR9460PNAH*1	2JH704-PF	2JH704-GF	0.75	reciprocating	3/8	3/8	159	9.50	S	R-454C R-455A
ASHR9480PNAH*1	2JH1013-PF	2JH1013-GF	1.00	reciprocating	3/8	3/8	159	9.50	S	
ASHR9510PNAH*1	2JH1016-PF	2JH1016-GF	1.25	reciprocating	1/2	5/8	234	22.15	M	R-404A R-448A R-449A R-454C R-455A
ASHR9510PFAH*1	2JH1017-PF	2JH1016-GF	1.25	reciprocating	1/2	5/8	234	22.15	M	
ASHR9512PNAH*1	2JH3208-PF	2JH3208-GF	1.50	reciprocating	1/2	5/8	234	22.15	M	
ASHR9512PFAH*1	2JH3209-PF	2JH3209-GF	1.50	reciprocating	1/2	5/8	234	22.15	M	
ASHS9516PNAH*1	2JH2020-PF	2JH2020-GF	2.00	scroll	1/2	5/8	234	22.15	M	
ASHS9516PFAH*1	2JH2024-PF	2JH2024-GF	2.00	scroll	1/2	7/8	234	22.15	M	R-404A R-448A R-449A R-454C R-455A R-454A
ASHS9520PNAH*1	2JH2026-PF	2JH2026-GF	2.50	scroll	1/2	7/8	234	22.15	M	
ASHS9520PFAH*1	2JH2027-PF	2JH2027-GF	2.50	scroll	1/2	7/8	234	22.15	M	
ASHS9522PNAH*1	2JH2021-PF	2JH2021-GF	2.75	scroll	1/2	7/8	234	22.15	M	
ASHS9522PFAH*1	2JH2025-PF	2JH2025-GF	2.75	scroll	1/2	7/8	234	22.15	M	
ASHS9524PNAH*1	2JH3010-PF	2JH3010-GF	3.00	scroll	1/2	7/8	347	36.26	L	
ASHS9524PFAH*1	2JH3011-PF	2JH3011-GF	3.00	scroll	1/2	7/8	347	36.26	L	
ASHS9532PNAH*1	2JH4003-PF	2JH4003-GF	4.00	scroll	1/2	1 1/8	347	36.26	L	
ASHS9532PFAH*1	2JH4004-PF	2JH4004-GF	4.00	scroll	1/2	1 1/8	347	36.26	L	
ASHS9540PNAH*1	2JH5005-PF	2JH5005-GF	5.00	scroll	1/2	1 1/8	347	36.26	L	
ASHS9540PFAH*1	2JH5006-PF	2JH5006-GF	5.00	scroll	1/2	1 1/8	347	40.65	L	
ASHS9548PFAH*1	2JH6003-PF	2JH6003-GF	6.00	scroll	1/2	1 1/8	347	40.65	L	
ASHS9563ZFAPPI	2JH8000-PF	-	8.00	scroll	7/8	1 3/8	480	64.20	XL	R-404A R-448A R-449A
ASHS9575ZFAPPI	2JH9000-PF	-	9.00	scroll	7/8	1 3/8	480	64.20	XL	
ASHS9583ZFAPPI	2JH10001-PF	-	10.00	scroll	7/8	1 3/8	480	64.20	XL	
ASHS9593ZFAPPI	2JH12000-PF	-	12.00	scroll	7/8	1 5/8	480	64.20	XL	

*pumpdown capacity at 32.2°C (90°F) 90%



CHASSIS SIZE (INCHES)

S CHASSIS

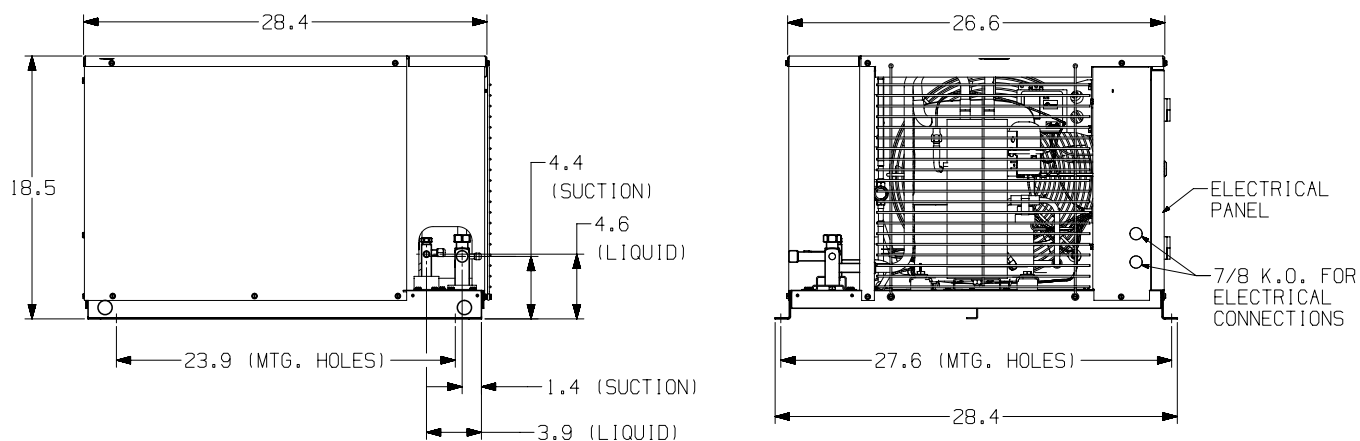

M CHASSIS

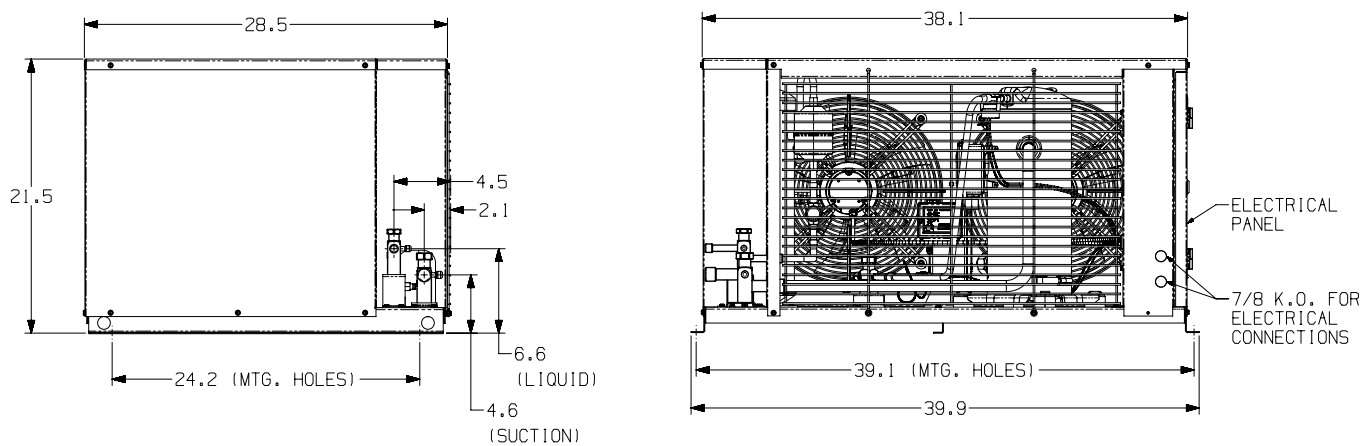

L CHASSIS

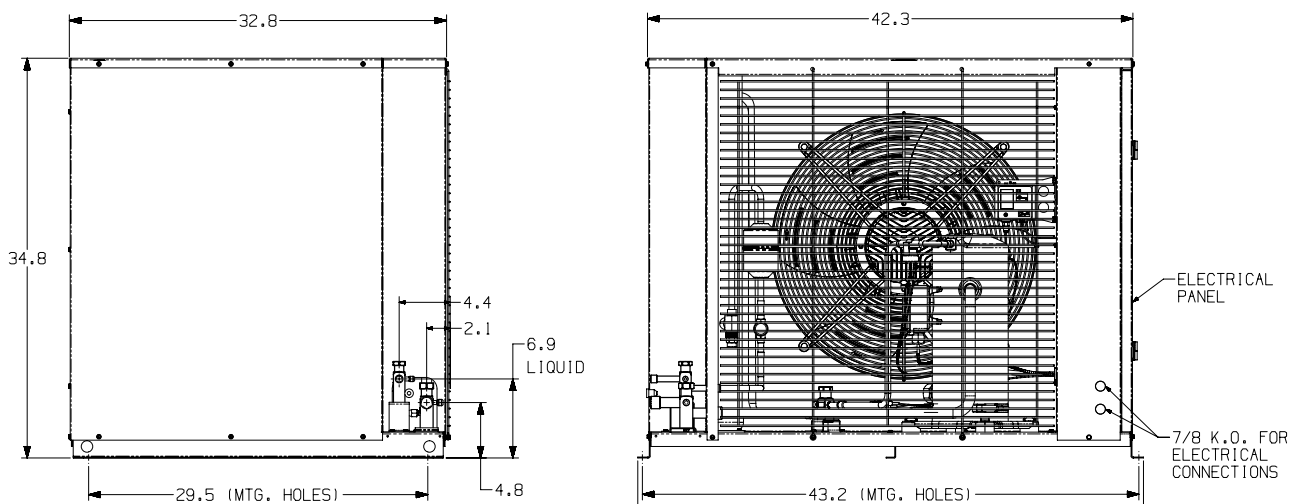



CHASSIS SIZE (INCHES)

XL CHASSIS

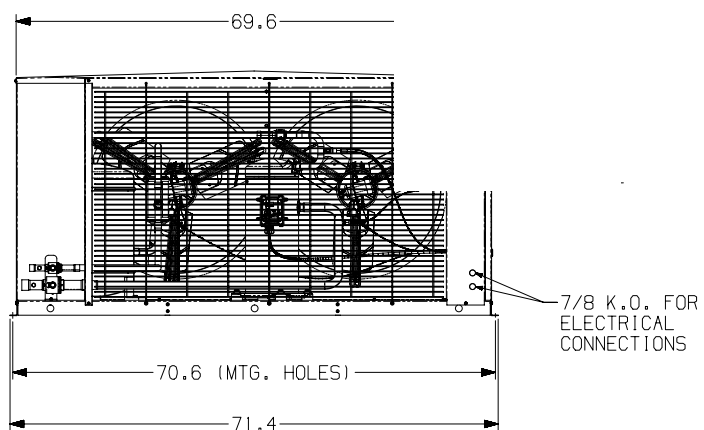
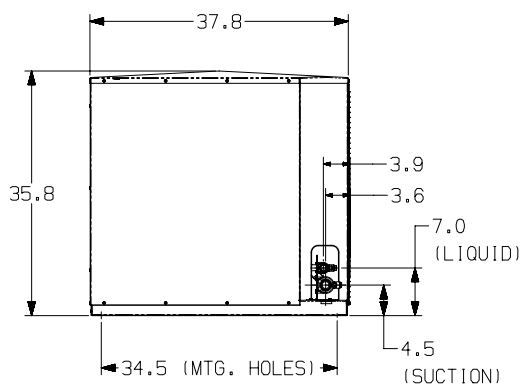

Preliminary data subject to change without notice.

TO FIND OUT MORE INFORMATION

- VISIT TECUMSEH.COM
- CONTACT OUR SALES REPRESENTATIVE

Produced by Tecumseh Products Company | All rights reserved | April 2026





tecumseh